

# **HIGHPOWER**

## **SECURITY PRODUCTS**

TEL: (203)-634-3900 FAX: (203)-238-2425  
EMAIL: [HIGHPOWER@HIGHPOWERSECURITY.COM](mailto:HIGHPOWER@HIGHPOWERSECURITY.COM)  
WEB: [WWW.HIGHPOWERSECURITY.COM](http://WWW.HIGHPOWERSECURITY.COM)

Dear Customer, if you are having problems using this product, please call Highpower Technical Support at 800-991-3646. We are here to help and we appreciate your business!

Dear Installer: When using the controller without connection to a fire alarm, place a wire jumper from terminals #57 and #60 for proper controller operation or use the V+ terminals for power.

MODEL 3000 MULTIFUNCTION DOOR CONTROLLER WITH DELAYED EGRESS

# HARDWARE MANUAL

FIRMWARE VERSION 2.1.0

DOCUMENT NUMBER: 980-3000-2.1.0

## **TABLE OF CONTENTS**

<b>CONTROLLER DESCRIPTION</b> .....	<b>2</b>
<b>KEY FEATURES</b> .....	<b>3</b>
<b>NOTICE OF INSTALLER QUALIFICATION</b> .....	<b>3</b>
<b>ACCESS CONTROL FEATURES</b> .....	<b>3</b>
CODE TYPES .....	3
SHADOW CARD SYSTEMS .....	3
MATRIX AND WIEGAND INTERFACES DESCRIBED .....	4
USING THE MATRIX KEYPAD .....	4
PROGRAMMABLE OUTPUT TIMERS .....	4
REMOTE RELEASE INPUTS .....	5
<b>DELAYED EGRESS FUNCTIONS</b> .....	<b>5</b>
DOOR POSITION SWITCH FEATURES .....	5
REQUEST TO EXIT OVERRIDE .....	6
<b>FIRE ALARM INTERFACE</b> .....	<b>6</b>
<b>ADDITIONAL CONTROLLER FEATURES</b> .....	<b>6</b>
VIDEO RECORDER OUTPUT .....	6
PANIC SIGNALLING .....	6
AUTOMATIC KEY PRESS CLEARING .....	7
WIEGAND LED CONTROL .....	7
LED INDICATOR OUTPUTS .....	7
BACKUP BATTERY PASS-THROUGH .....	7
EEPROM MEMORY .....	7
SELF-RESETTING DESIGN .....	7
CODES SPECIFIC TO EACH READER .....	7
<b>HARDWARE CONNECTION</b> .....	<b>7</b>
POWER CONNECTION .....	7

FIRE ALARM PREPARATION .....	8
REMOTE RELEASE .....	8
REMOTE RELEASE WIRE CONNECTION DIAGRAM .....	8
WIEGAND PORTS.....	9
WEIGAND PORT WIRE CONNECTION DIAGRAM.....	9
TESTED BRANDS OF WIEGAND DEVICES.....	10
PROXIMITY READERS.....	10
BAR CODE READERS.....	10
MAG-STRIPE READERS .....	10
DELAYED EGRESS PORT .....	10
DELAYED EGRESS PORT WIRE CONNECTION DIAGRAM .....	11
LED INDICATOR OUTPUTS.....	12
LED INDICATOR OUTPUTS WIRE CONNECTION DIAGRAM .....	12
EXTERNAL MATRIX KEYPAD PORT .....	13
MATRIX KEYPAD WIRE CONNECTION DIAGRAM.....	13
RELAY OUTPUTS 1 AND 2.....	14
RELAY OUTPUT 1 WIRE CONNECTION DIAGRAM EXAMPLE .....	15
RELAY OUTPUT 2 WIRE CONNECTION DIAGRAM EXAMPLE .....	16
CONNECTING A PROXIMITY DETECTOR TO A RELAY OUTPUT .....	17
TRANSISTOR OUTPUTS 3 AND 4.....	18
TRANSISTOR OUTPUTS 3 AND 4 WIRE CONNECTION DIAGRAM EXAMPLE .....	18
FIRE ALARM INTERFACE.....	18
FIRE ALARM INTERFACE WIRE CONNECTION WITH AUTOMATIC RESET.....	20
BATTERY PASS-THROUGH.....	21
<b>LED INDICATOR FUNCTIONS .....</b>	<b>21</b>
<b>APPLICATIONS .....</b>	<b>22</b>
SAFELY WIRING THE CONTROLLER WITH AN ELECTROMAGNETIC LOCK AND A PNEUMATIC PUSHBUTTON.....	22
SAFELY WIRING THE CONTROLLER WITH AN ELECTROMAGNETIC LOCK, PNEUMATIC PUSHBUTTON AND PIR SENSOR .....	23
USING TOGGLE CODES TO LEAVE A DOOR UNLOCKED.....	24
WIRING DIAGRAM USING TOGGLING OUTPUTS TO LATCH A DOOR IN PASSAGE	24
USING A TRANSISTOR OUTPUT TO CONTROL AN ELECTROMAGNETIC LOCK .....	25
TRANSISTOR OUTPUTS WITH FAIL-SAFE DEVICES WIRING DIAGRAM.....	25
CONTROLLING FOUR DOORS WITH THE MODEL 3000 .....	26
MAN-TRAPS (FOR CLEAN ROOMS).....	26
<b>THIRD-PARTY ADD-ON PERIPHERALS .....</b>	<b>27</b>
<b>CUSTOM WIRING DIAGRAMS AND UNIQUE APPLICATIONS .....</b>	<b>28</b>
<b>WARRANTY INFORMATION.....</b>	<b>28</b>
<b>TROUBLESHOOTING ISSUES .....</b>	<b>29</b>
<b>TYPICAL SYSTEM RISER DIAGRAM.....</b>	<b>30</b>

## CONTROLLER DESCRIPTION

The Highpower Multifunction Door Controller is a control circuit used to provide delayed egress for one door and access control functions for two doors. The controller is designed to store access codes by interfacing with keypads, card readers and biometrics, and can control electromagnetic locks and electric strikes. Additionally, the controller can be used to interface locks with a fire alarm, can turn on video recorders during door activity and can provide alarms for unsecured door conditions. This document will describe the features of this controller for simplified installation and setup.

## KEY FEATURES

- Delayed Egress Controller with BOCA and NFPA 101 compatibility modes. Controller provides both an audible and visual LED response on one door.
- Integrated Access Control with both 26-Bit Wiegand Input and 7-Wire Matrix Keypad Input. Unit can store 510 users in non-volatile EEPROM memory. Access control module is designed to work with two doors.
- Wiegand interface has automatic transmission speed adjustment for compatibility with 26-bit Wiegand readers from many different manufacturers.
- Wiegand port supports multiple Wiegand devices connected simultaneously.
- Integrated Fire Alarm Relay for interfacing the controller to a fire alarm system.
- Four main outputs controlled by five timers. Two outputs are 15 Amp relay outputs and two are 10 Amp FET Transistor outputs.
- Outputs are fused and have surge suppression circuitry.
- Door Monitoring on one door with LED response including Anti-Tailgating and Forced Door Alarm.
- Active Camera output for turning on video cameras and recorders during door events.
- Fully stand-alone programmable through integrated keypad and led indicators.

## NOTICE OF INSTALLER QUALIFICATION

The items listed in this manual may require the services of an individual who is trained in the application and installation of life safety equipment. All wiring must be in compliance with current NEC guidelines.

## ACCESS CONTROL FEATURES

### **CODE TYPES**

The access control portion of the controller has a memory that is able to hold 510 codes. You may program codes in memory that can be of six types. Code types include master codes, user codes, one-time-use codes, “programming add” codes and “programming remove” codes.

Master codes are codes that allow access to programming features. These codes should only be given to system administrators. They allow an administrator to enter programming mode.

User codes are codes that activate outputs, but do not allow access to programming features. These codes are given to users for entry.

“One-Time-Use” codes are often called “Service Codes”. These are codes that only allow access one time. These codes can be given to maintenance people or real-estate salespeople to provide one-time entry into a door. Since any code can be a one-time-use code, you can have up to 510 one-time-use codes in memory. You may make a particular one-time-use code work for more than one time. By adding the code to memory multiple times, the code will work for as many times as it was programmed.

### **SHADOW CARD SYSTEMS**

A new feature added to the controller (with Firmware Version 2.0.0) is support for a “Shadow Card Systems”. Shadow Card Systems are systems that are designed to simplify the management of user codes.

In a basic shadow card system, there are two identically coded cards for every user. One of the cards is issued to the user. The second card is kept with administration. In addition to the sets of user

cards, there are two special cards. These cards are the “Programming Add” and “Programming Remove” cards.

When Programming Add card is swiped, the controller enters a special programming mode. All cards swiped after the Programming Add card, are stored in memory as a user card. The Programming Add card is then swiped at the end of adding all of the user cards, exiting the add mode. All cards swiped at a particular reader will only work on that reader. If the card is already in memory, the controller will not allow the addition of the card a second time.

Programming Remove cards allow administration to delete a user code, when a user must be removed from the system. By swiping the Programming Remove card at a particular reader, the controller enters another programming mode. Every card swiped after the Programming Remove card is removed from memory. The second user card that was kept with administration for a particular user is used in the case where a user card has not been returned or is damaged. This programming mode deletes all instances of the swiped code in memory for a particular reader. When all the desired codes have been removed, the same Programming Remove card is again swiped in order to return back to normal operation. These operations can be performed with no keystrokes on the keypad and is fast and simple for maintaining a few user codes.

## **MATRIX AND WIEGAND INTERFACES DESCRIBED**

There are two interfaces that can be used to send codes to the controller. The controller has both a matrix keypad interface and two 26-Bit Wiegand interfaces. The matrix keypad interface allows the installer to connect a standard matrix keypad to the controller. The matrix keypad can be used for both access and programming. Multiple matrix keypads can be connected to the matrix keypad port for this purpose.

In addition to the matrix keypad input, the controller has two Wiegand interfaces can be used to connect the controller to any standard 26-bit Wiegand device. Since the Wiegand device only sends ID numbers back to the controller, the matrix keypad must be used for most programming sequences. For convenience, there is a matrix keypad mounted on the controller’s board, so that users who use just the Wiegand ports can readily program the unit.

This controller does not use the site code portion of the 26-bit Wiegand data. The controller is designed to store the lower 16-bits of the data values in order to store codes. Despite this, the Highpower Wiegand Interface provides full Data Parity Checking over the entire 26-bits to ensure code integrity. In addition, the Wiegand interface is fully signal de-bounced, in order to filter noisy Wiegand data, and has automatic detection of data transmission rate, so that 26-bit Wiegand devices from many brands should work properly. The interface will timeout and recover in the case where the Wiegand data transmission is incomplete or corrupted.

## **USING THE MATRIX KEYPAD**

The matrix keypad can be used to both program the controller, and send user codes to the controller. User codes that have been stored in memory as “Reader 1” codes can be activated using the matrix keypad. For example, if you program the controller to unlock on Port 1 with the code “1234”, code “1234” will work when the code is entered on the Wiegand Reader 1 or the matrix keypad.

## **PROGRAMMABLE OUTPUT TIMERS**

The controller has 4 programmable outputs. Two of these outputs are 15 Amp relays and the other two are 10 Amp FET (transistor) outputs. These outputs control up to a 35V control voltage.

Access codes are individually programmed to actuate output timers. There are five output timers in the controller. The first two output timers activate output 1 (relay) and the additional three timers are assigned to Outputs 2 through Outputs 4.

When a code is entered, the controller looks up which output timer(s) the code is programmed to actuate. The duration of each of these timers is programmable. Since each output has a timer associated to it, the output stays unlocked for the programmed time when actuated. If the timers are programmed to open for “zero” seconds, the output will toggle instead of time.

Since Relay 1 has two output timers associated with it, you can have two different unlock delays for Door 1. This feature is commonly used to provide handicapped access. The second timer can be set for a longer duration, so that Door 1 is left unlocked for a longer time when a handicapped user is trying to enter.

## REMOTE RELEASE INPUTS

In addition to using codes to activate timers, two “remote release” inputs on the controller can be used. The remote release inputs will activate Timer 1 and Timer 2 with an external signal. This signal can be a pushbutton or other type of switch that is used to unlock a door from a remote location. **Do not rely on these inputs as a sole form of egress. For most systems, it is required to have (2) forms of egress, one using the controller, and a second, such as a pneumatic push button switch, that directly cuts the power to an electromagnetic lock.** This port is useful when using electronic devices for egress like a proximity sensor or remote pushbutton.

## DELAYED EGRESS FUNCTIONS

The controller is designed to provide delayed egress functions on Door 1 in addition to access control functions. The “delayed egress cycle” is a timed unlock of Door 1 that is triggered by a “Request to Exit” input. This feature is used to allow users to exit out of a locked door after waiting for a 15 or 30 second unlock countdown. There are two standards for this type of operation. These standards are described in BOCA and NFPA 101 documentation.

In NFPA mode, the controller starts counting down after the Request to Exit input is actuated. There is a 2 second nuisance delay on the Request to Exit input that prevents false alarms. After a user holds down the request to exit device for more than two seconds, the delayed egress countdown begins. The countdown duration is programmable between 15 and 30 seconds. For the next 15 or 30 seconds, the controller “beeps” an audible output and interchanges the led colors between green and red. At the end of the countdown period, Output 1 unlocks, allowing the user to egress. Once the door is unlocked, the audible alarm stays on continuously and the Red LED is lit. The unit stays in this state until a manual reset procedure occurs. An administrator must (1) open the door for more than one second, (2) close the door and actuate a “manual reset” switch. This switch is usually a key-switch. After doing the reset, the alarm is halted and the controller returns to run mode.

In BOCA mode, a similar countdown occurs but the reset procedure is different. At the end of the unlock cycle, a second relock cycle takes place. The relock cycle occurs once the door has been opened and then re-closed. This relock cycle relocks the door automatically. If the door is re-opened during this 30 second relock cycle, the relock cycle starts over again. This ensures that there is always a 30 second window between user passages.

## DOOR POSITION SWITCH FEATURES

Because both of the delayed egress modes rely on the opening and closing of the door, a Door Position Switch (DPS) must be used. Typically, this is a magnetic reed switch that is part of an electromagnetic lock, or a latch sensor in an electric strike. There is an input in the Delayed Egress Terminal Block that provides a connection for this switch.

When using a DPS, the controller provides additional features. These features include an anti-tail-gating feature and a forced door alarm feature on Door #1. The anti-tail-gating feature will relock

Output 1 immediately after a door closure. This prevents another user from “tail-gating”; tail-gating is passing through the door immediately after another user has entered their code, effectively allowing two people to pass using the first user’s code.

The Forced Door Alarm is triggered when the locking mechanism of a door is defeated. In this case, the door is supposed to be locked, but the door position sensor is open. When this occurs, the audible alarm turns on in order to alert a guard or administrator. The video recorder output is also activated.

## **REQUEST TO EXIT OVERRIDE**

The delayed egress key switch is used to reset the controller when the controller is in NFPA 101 mode. After counting down, the door unlocks and the controller waits until an administrator performs a reset using the key switch. Normally, this key switch is a momentary type switch. If you use a two-position maintained type key switch, instead of the momentary type, the key switch can be used to override the delay egress countdown. When the countdown is overridden, the request to exit switch will act as a remote release switch, instead of triggering the delayed egress cycle. This allows an administrator to use the request to exit device to act as a remote release during special occasions. In doing this the remote release device will allow immediate passage through door 1. Turning the key switch back to the run position will cause the controller to perform the delayed egress countdown.

## **FIRE ALARM INTERFACE**

The controller has a relay circuit that is used to interface with a fire alarm system. This relay is a latching relay circuit that can immediately cut the power to a connected electromagnetic door lock. In addition to cutting power to a lock, there are relay outputs that can be used for monitoring the status of the fire alarm.

This fire alarm relay circuit (FAR) can be configured for both manual and automatic reset. In the manual configuration, the unit will not re-energize an electromagnetic lock unless an external manual reset is actuated. This manual reset is typically a key-switch. In the automatic configuration, the power is restored to the locks when the fire alarm is reset. **Whenever the fire alarm circuit is used, check with the Authority Having Jurisdiction for approval of the proposed system connections.**

When using the controller without connection to a fire alarm, place a wire jumper from terminals #57 and #60 for proper controller operation.

## **ADDITIONAL CONTROLLER FEATURES**

### **VIDEO RECORDER OUTPUT**

There is an output on the controller that is specifically designed to trigger an event on a video recorder. This output is activated when (1) a push on a key on a matrix keypad occurs, (2) a code is sent to the controller over one of the Wiegand ports, or (3) the Door Position Switch is open due to an alarm. This output is programmed to stay on for 8 seconds after the event ends. If another event that occurs during the timing cycle, the second event will cause the cycle to restart.

### **PANIC SIGNALLING**

The controller has a special mode that can be used for panic emergencies or external signaling. If the matrix keypad is installed as an access device, a user can press both “\*” and “#” on the keypad to activate panic mode. Panic mode will activate programmed output timers. The programmed outputs can be used to signal a guard or administrator that there is a panic situation. The outputs that the panic mode activates can be programmed.

## **AUTOMATIC KEY PRESS CLEARING**

The controller will dump any key presses that are entered on the matrix keypad if the code is not completed in 8 seconds. This feature is disabled when the controller is in programming mode.

## **WIEGAND LED CONTROL**

The Wiegand LED control lines reflect the conditions of Relay 1 and Relay 2. If Relay 1 is triggered, the LED Control Line on Wiegand Port 1 changes the state of the LED on the Wiegand Device that is connected to Port 1. If Relay 2 is triggered, the LED Control Line on Wiegand Port 2 changes the state of the LED on the Wiegand Device that is connected to Port 2.

## **LED INDICATOR OUTPUTS**

The controller has outputs for driving external LED indicators. There is an output for the Red, Amber and Green status LEDs. These outputs allow for external monitoring of the controller status and provide indications during the Delayed Egress Modes.

## **BACKUP BATTERY PASS-THROUGH**

The controller provides wires that pass the voltage of a back up battery through to an external power supply.

## **EEPROM MEMORY**

The EEPROM memory on the controller stores all 510 codes and features settings. This data is retained no matter if there is power to the controller or not. This memory has been tested to perform over 1,000,000 write cycles, and can provide an infinite number of read cycles. The unit should retain data for over 90 years without external power. The controller performs internal operations that self-tests the EEPROM memory, and fully verifies all of the codes that are added to the memory.

## **SELF-RESETTING DESIGN**

The processor of this controller is designed to reset itself if circuit faults should occur.

## **CODES SPECIFIC TO EACH READER**

When a user code is added to the controller, the controller stores which port the code is to be used on. User codes can be programmed to work on either Reader 1 or Reader 2. In doing this, codes for a two-door system remain independent to each of the doors.

## **HARDWARE CONNECTION**

### **POWER CONNECTION**

The supply power connections are made at terminals 61 and 60. The maximum supply voltage is 35 VDC.

<b>TERMINAL #</b>	<b>NAME</b>	<b>FUNCTION</b>
62	(+V)	DC Supply Voltage 35 VDC Maximum
61	GND	DC Supply Ground

## FIRE ALARM PREPARATION

If the Model 3000 is not being connected to an external fire alarm system, then you must place a jumper from terminal 60 to terminal 57. If you do not do this, the fire alarm system will not provide power to the lock outputs (V<sub>F</sub>). If you are using a fire alarm, be sure to connect the fire alarm system in the manner described in the *Fire Alarm Connection* sections.

## REMOTE RELEASE

The Remote Release Terminals provide a connection for external switches that are used to trigger Timer 1 or Timer 2. By activating these timers, the external switches can be used for the remote release of Door 1 or Door 2.

<b>TERMINAL #</b>	<b>NAME</b>	<b>FUNCTION</b>
1	Remote Release 1	Opening the Loop from this terminal to ground triggers Timer 1
2	GND	DC Supply Ground
3	Remote Release 2	Opening the Loop from this terminal to ground triggers Timer 2

### REMOTE RELEASE WIRE CONNECTION DIAGRAM

*Remote Release  
Terminal Block  
TRM0:*

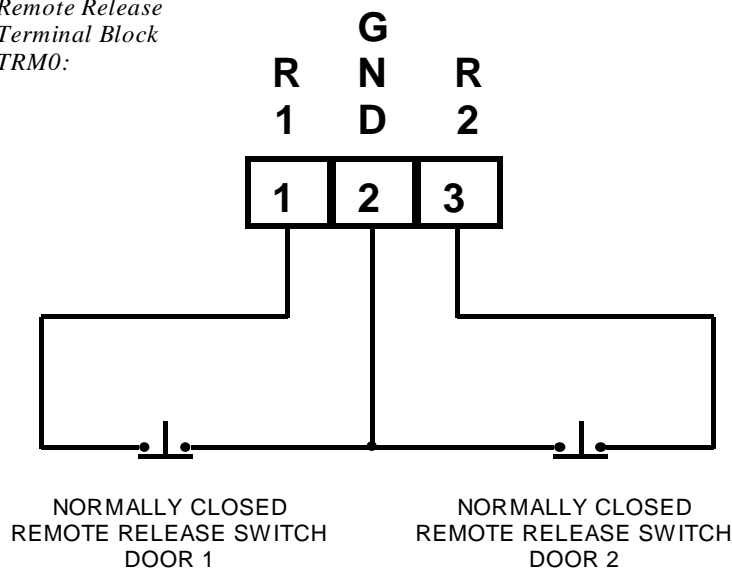

NOTE: When using the Remote Release feature, make sure to enable the remote release by setting the corresponding Remote Release Jumper (JP3 or JP4).

## WIEGAND PORTS

The controller has two 26-Bit Wiegand Ports for connection of two Wiegand Devices. Terminals 4 through 9 construct Wiegand Port 1. Terminals 10 through 15 construct Wiegand Port 2.

<b>TERMINAL #</b>	<b>NAME</b>	<b>FUNCTION</b>
Port 1:		
4	(+V)	DC Supply Voltage 35 VDC Maximum
5	(+5V)	(+5) VDC Regulated
6	GND	DC Supply Ground
7	PORT 1:D0	Port 1 Wiegand Data 0 Input
8	PORT 1:D1	Port 1 Wiegand Data 1 Input
9	PORT 1 LED CTRL	Port 1 LED Control Line Output
Port 2:		
10	(+V)	DC Supply Voltage 35 VDC Maximum
11	(+5V)	(+5) VDC Regulated
12	GND	DC Supply Ground
13	PORT 2:D0	Port 2 Wiegand Data 0 Input
14	PORT 2:D1	Port 2 Wiegand Data 1 Input
15	PORT 2 LED CTRL	Port 2 LED Control Line Output

Led Control Lines change the state of the LED on the Wiegand Device. The LED on the first Wiegand Port indicates the state of Relay Output 1. The LED on the second Wiegand Port indicates the state of Relay Output 2.

### WEIGAND PORT WIRE CONNECTION DIAGRAM

*Wiegand Port 1  
Terminal Block  
TRM1:*

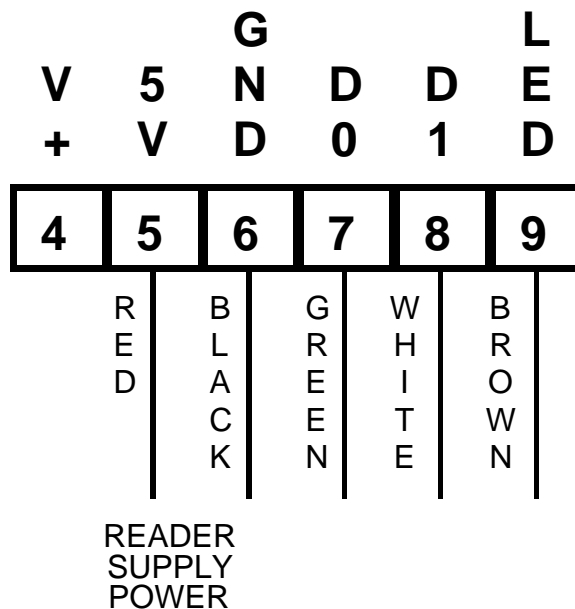

## **TESTED BRANDS OF WIEGAND DEVICES**

Highpower strives to make the Model 3000 as compatible as possible with Wiegand devices from many manufacturers. In accordance with this goal, we have created our Wiegand interface to automatically detect the transmission speed of any Wiegand device connected.

As a result, we are compiling a list of Wiegand devices that have been tested with the Model 3000. These devices include the following:

### **PROXIMITY READERS**

#### **All 26-Bit Wiegand “Revision D” model readers from AWID (Applied Wireless ID, Inc.)**

Note: This brand is highly recommended for use with the Model 3000.

#### **26-Bit Wiegand “Pyramid” Reader Heads from Keri Systems. (Models 300H, 500H).**

Note: These are good readers to use if you require HID Card compatibility.

### **BAR CODE READERS**

#### **All 26-bit Wiegand models from IBC (International Bar Code, Inc.)**

Note: Use the “Smart” models of IBC products when using extended bar codes.

### **MAG-STRIPE READERS**

#### **All 26-Bit Wiegand models from IBC (International Bar Code, Inc.)**

Note: Use the “Smart” models of IBC products when using custom track configurations.

Note to Installers: If you have successfully used another brand of reader with our controller or are having problems with a particular model of reader, we want to hear from you! Your comments are appreciated. Please call us direct at 800-991-3646.

Note to Hardware Manufacturers: If you would like us to test your access control product with this controller, please contact Highpower directly. We would be pleased to add your qualified product to our list.

## **DELAYED EGRESS PORT**

The Delayed Egress Terminal Block has inputs for the Request to Exit, Door Position Switch, External Reset key-switch and an Output for the Audible Alarm (Sonalert).

<b>TERMINAL #</b>	<b>NAME</b>	<b>FUNCTION</b>
16	GND	DC Supply Ground
17	REX	Request to Exit Loop Input
18	GND	DC Supply Ground
19	DPS	Door Position Switch Input
20	GND	DC Supply Ground
21	RST	External Key-Switch Reset Input
22	SON	Audible Signal Output (100 mA MAX)
23	GND	DC Supply Ground

**DELAYED EGRESS PORT WIRE CONNECTION DIAGRAM**

*Delayed Egress Port  
Terminal Block  
TRM3:*

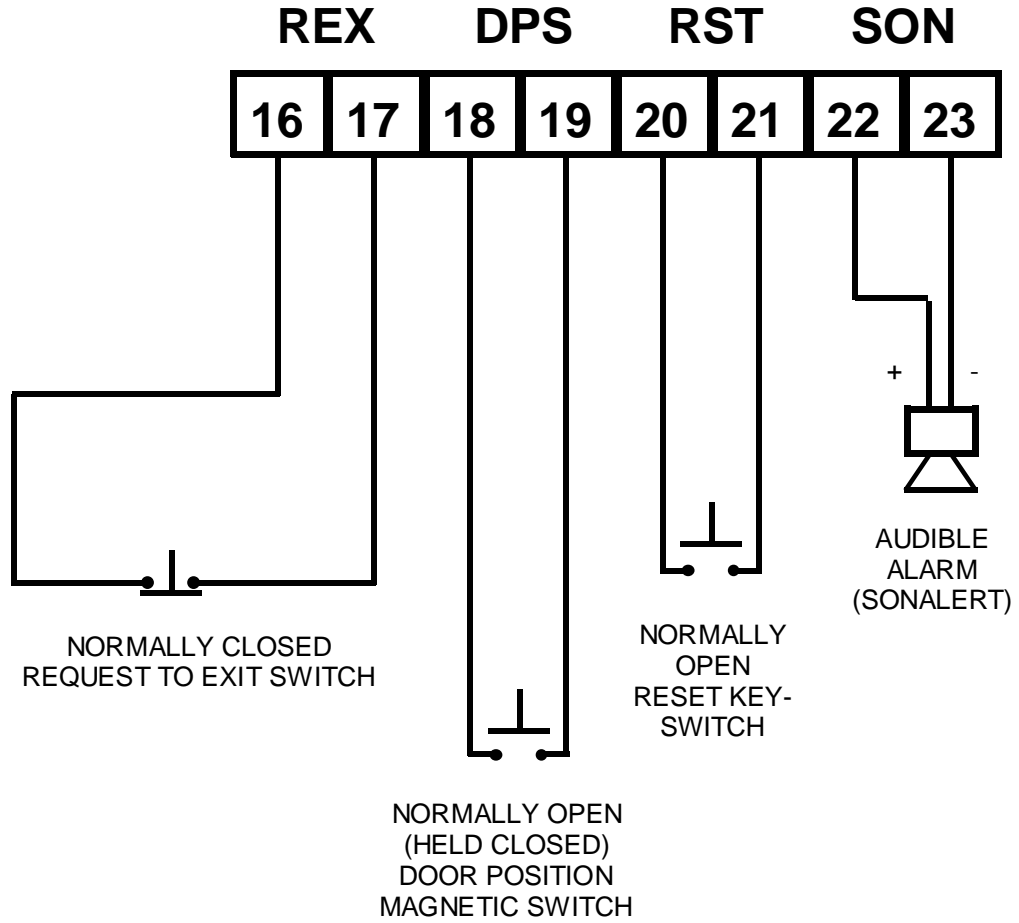

## LED INDICATOR OUTPUTS

The LED Indicator outputs are used to monitor the status of the controller externally. These signals are usually sent to indicators that are mounted externally with the matrix keypad. There is an output in this terminal block group called "ACT" (active) that is used to trigger a video recorder during events. These outputs can also be used to power small relays (< 100 mA).

TERMINAL #	NAME	FUNCTION
24	5V	(+5) Volt regulated voltage for external LED power.
25	GREEN	Green Status LED Transistor Output
26	AMBER	Amber Status LED Transistor Output
27	RED	Red Status LED Transistor Output
28	ACT	Event Active Output used to trigger a video recorder
29	GND	DC Supply Ground

### LED INDICATOR OUTPUTS WIRE CONNECTION DIAGRAM

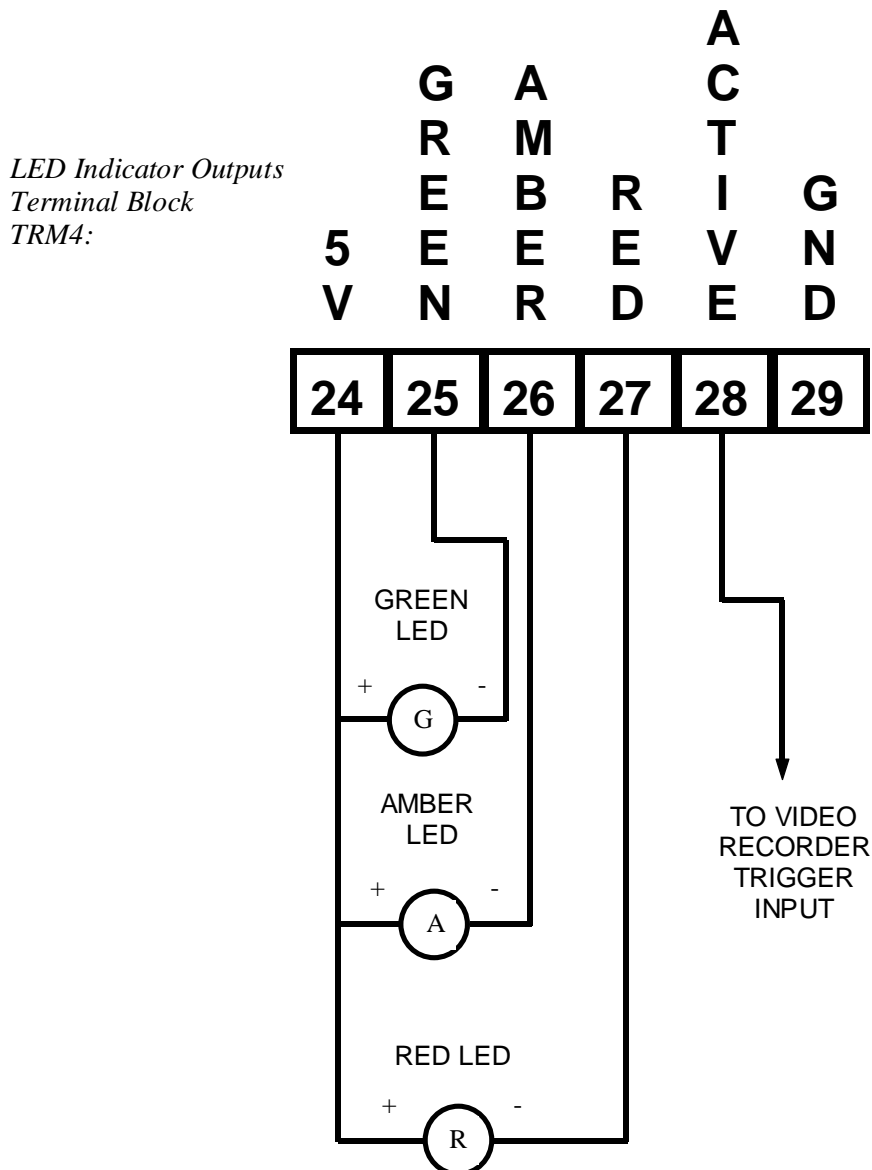

## EXTERNAL MATRIX KEYPAD PORT

An external matrix keypad can be connected to the controller. This keypad can both be used as an access device or a programming interface. Using the matrix keypad externally also allows for Panic Signaling.

<b>TERMINAL #</b>	<b>NAME</b>	<b>FUNCTION</b>
30	C1	Matrix Keypad Column 1
31	C2	Matrix Keypad Column 2
32	C3	Matrix Keypad Column 3
33	R1	Matrix Keypad Row 1
34	R2	Matrix Keypad Row 2
35	R3	Matrix Keypad Row 3
36	R4	Matrix Keypad Row 4
37	SH	Keypad Shield Grounding

### MATRIX KEYPAD WIRE CONNECTION DIAGRAM

*Matrix Keypad  
Terminal Block  
TRM5:*

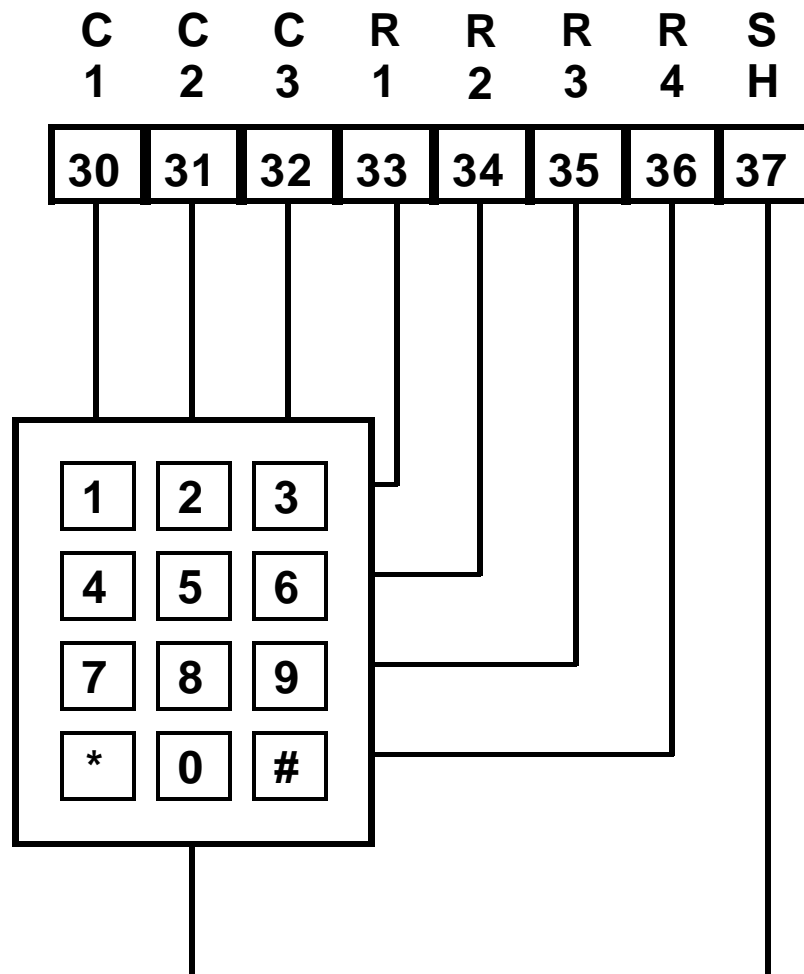

## **RELAY OUTPUTS 1 AND 2**

The relay outputs have a common configuration. These outputs are used mainly to run an electromagnetic lock or electric strike. The maximum current that can be switched by these outputs is 15 Amps.

<b>TERMINAL #</b>	<b>NAME</b>	<b>FUNCTION</b>
Output 1:		
38	VF	Supply Voltage from Fire Alarm Relay
39	NC	Normally Closed relay contact
40	C	Common relay contact
41	NO	Normally Open relay contact
42	(+V)	DC Supply Voltage 35 VDC Maximum
43	GND	DC Supply Ground
Output 2:		
44	VF	Supply Voltage from Fire Alarm Relay
45	NC	Normally Closed relay contact
46	C	Common relay contact
47	NO	Normally Open relay contact
48	(+V)	DC Supply Voltage 35 VDC Maximum
49	GND	DC Supply Ground

See connection diagram on next page.

## RELAY OUTPUT 1 WIRE CONNECTION DIAGRAM EXAMPLE

Relay Output  
Common  
JP7:

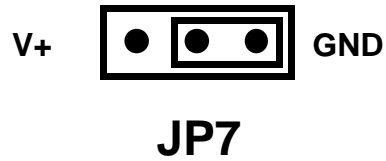

Note: This jumper is used to connect the common of Relay 1 to either Ground, V+ or neither.

Relay Output  
Terminal Block  
TRM6:

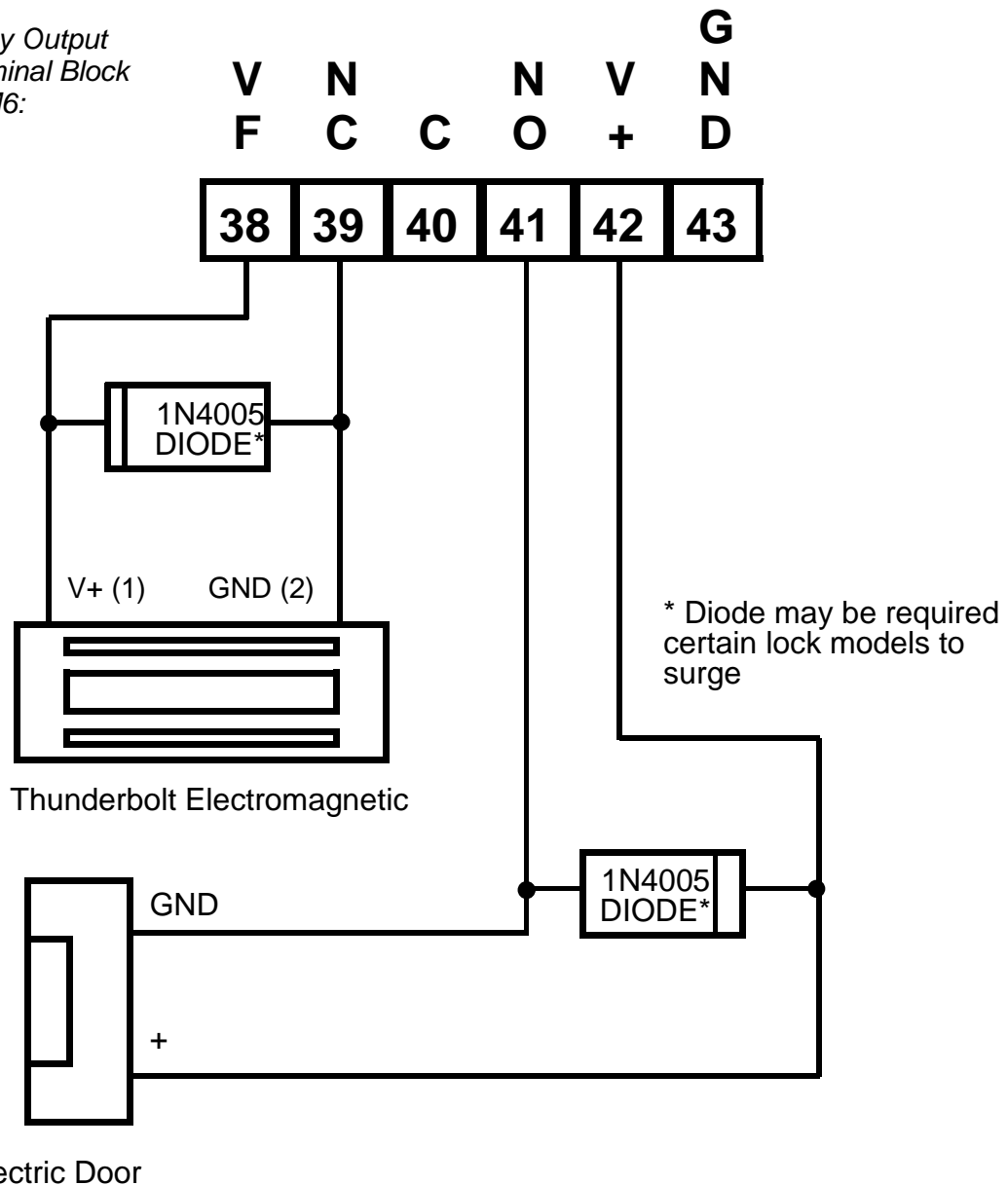

**RELAY OUTPUT 2 WIRE CONNECTION DIAGRAM EXAMPLE**

*Relay Output 2  
Common Jumper  
JP8:*

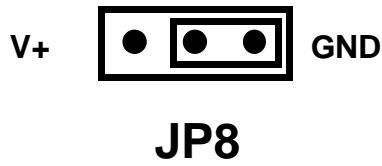

Note: This jumper is used to connect the common of Relay 2 to either Ground, V+ or neither.

*Relay Output 2  
Terminal Block  
TRM7:*

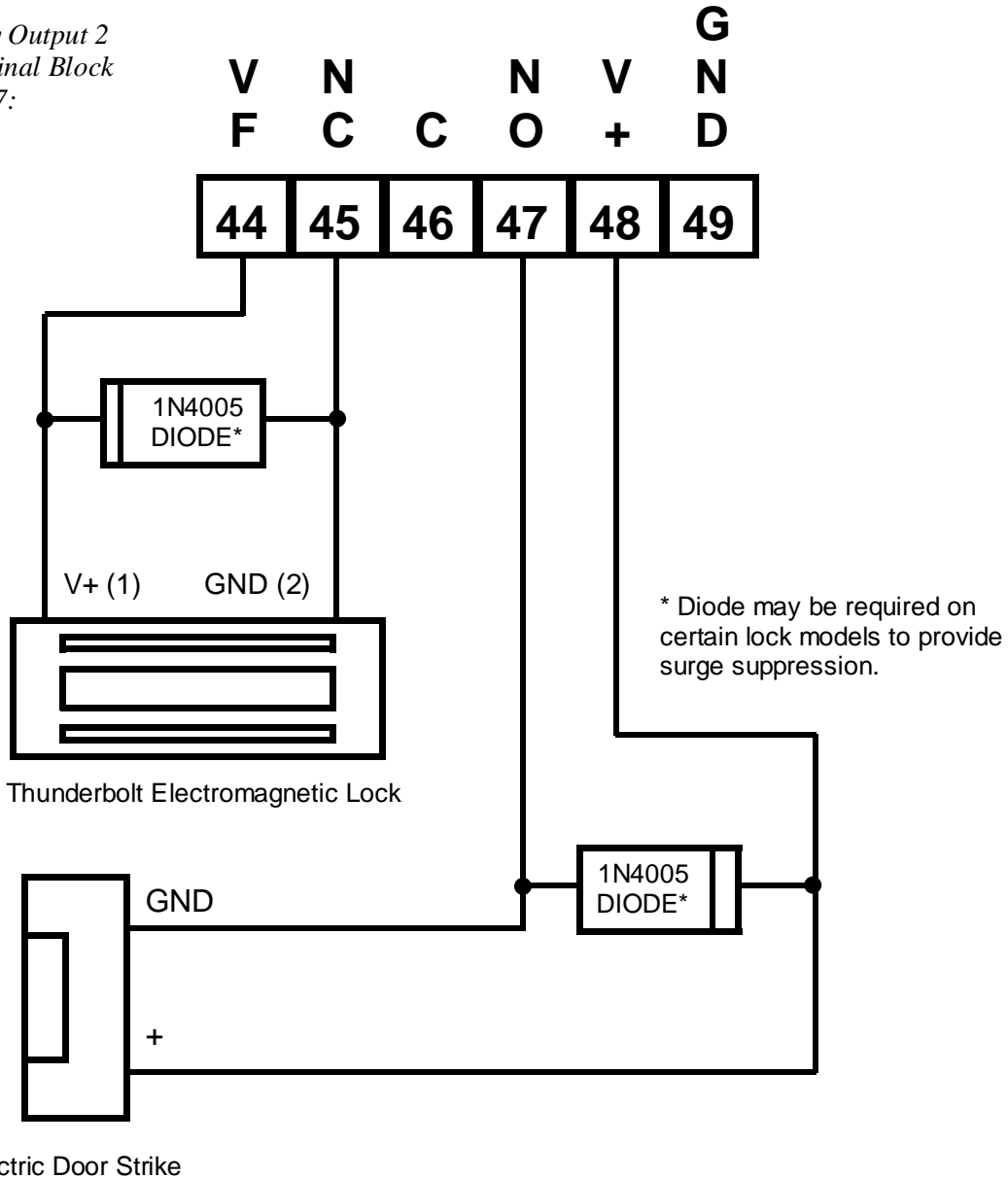

**CONNECTING A PROXIMITY DETECTOR TO A RELAY OUTPUT**

*Relay Output 1  
Common Jumper  
JP7:*

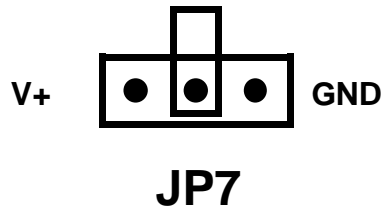

Note: This jumper is used to connect the common of Relay 1 to either Ground, V+ or neither. Remove the jumper for this configuration.

*Relay Output 1  
Terminal Block  
TRM6:*

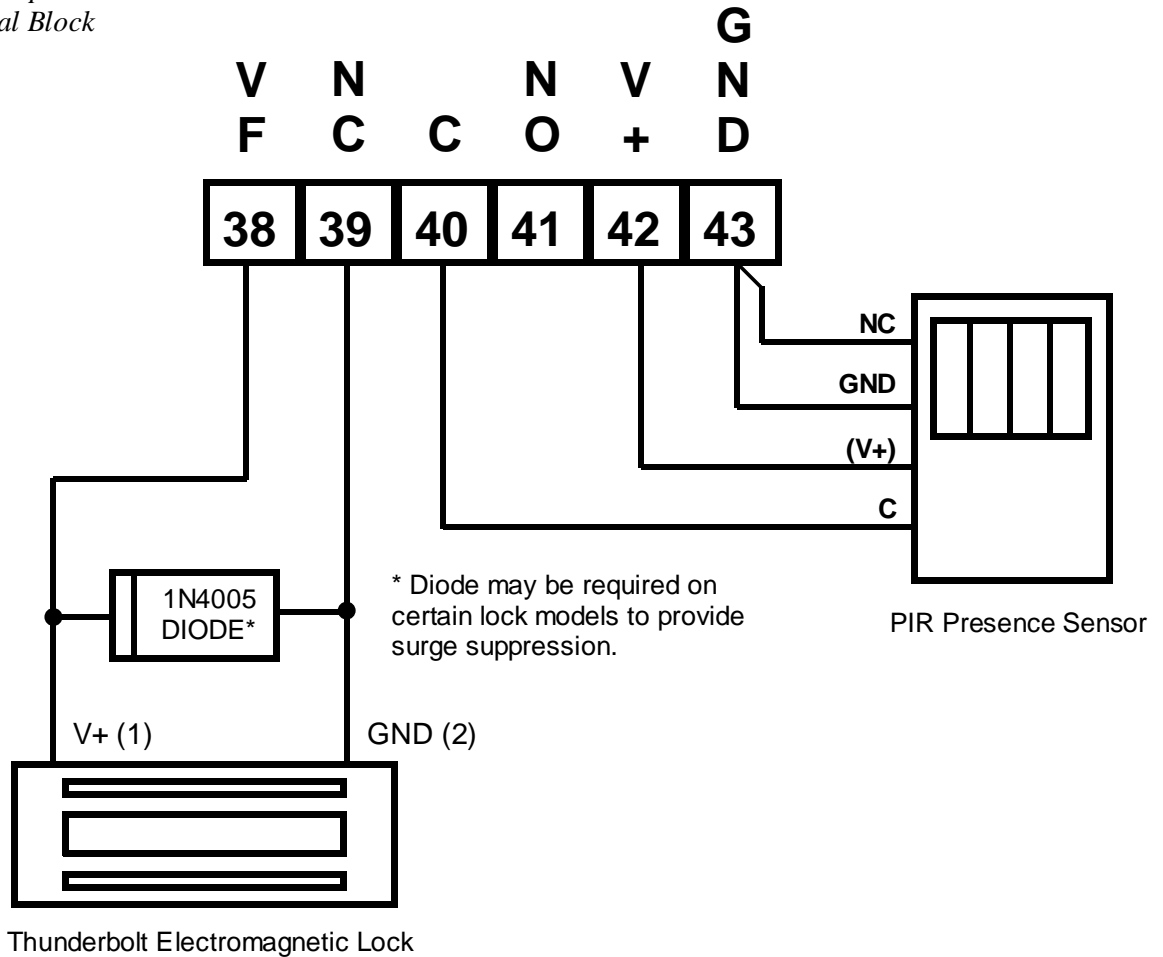

## TRANSISTOR OUTPUTS 3 AND 4

The transistor outputs have a common configuration. These are auxiliary outputs that can run external indicators, counters or extra access control devices. The maximum current that can be switched by these outputs is 5 Amps.

TERMINAL #	NAME	FUNCTION
50	VF	Supply Voltage from Fire Alarm Relay
51	3	Transistor Output 3
52	4	Transistor Output 4
53	(+V)	DC Supply Voltage 35 VDC Maximum

## TRANSISTOR OUTPUTS 3 AND 4 WIRE CONNECTION DIAGRAM EXAMPLE

*Transistor Outputs  
3 + 4 Terminal Block  
TRM8:*

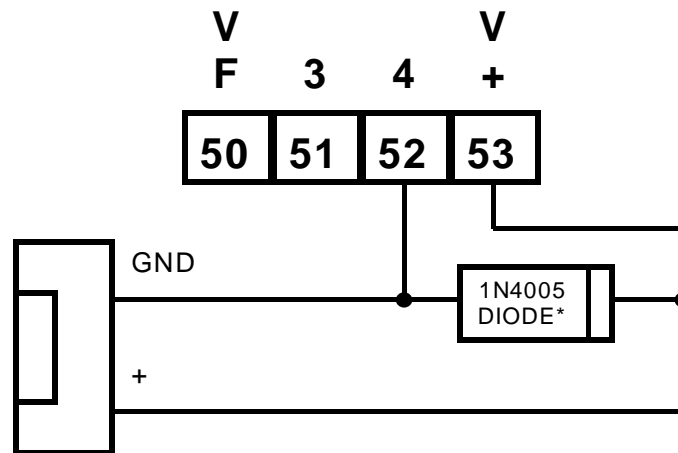

Electric Door Strike

\* Lock models without surge suppression require a diode to suppress voltage kickback.

## FIRE ALARM INTERFACE

The fire alarm interface is a latching relay that is used to connect the controller to the fire alarm. The interface controls the “VF” signal in the output terminal blocks. By using the “VF” signal to power an electromagnetic lock, the power is cut immediately when the fire alarm is triggered. Please contact your local fire authority as to the configuration of the Fire Alarm Relay Circuit.

TERMINAL #	NAME	FUNCTION
54	TRIPPED	External Monitoring - Tripped Fire Alarm Relay (Supply Voltage)
55	GND	DC Supply Ground
56	OK	External Monitoring - Fire Alarm Relay OK (Supply Voltage)
57	RST	External Reset Switch
58	RST	External Reset Switch
59	CON	External Fire Alarm Dry Contact
60	CON	External Fire Alarm Dry Contact

See connection diagram on next page.

# FIRE ALARM INTERFACE WIRE CONNECTION WITH MANUAL EXTERNAL RESET

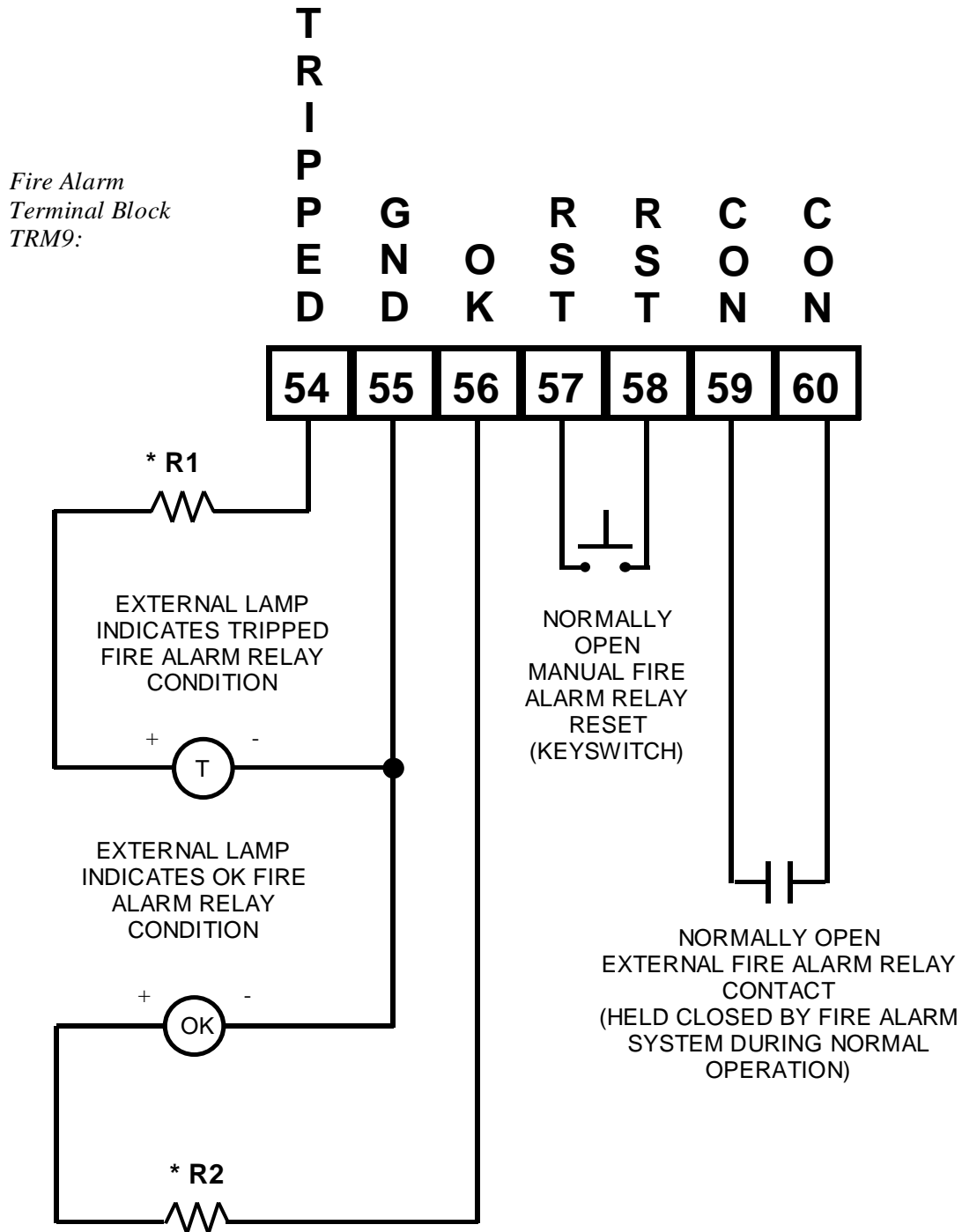

\* NOTE: Since the output voltage of the “TRIPPED” and “OK” terminals is (V+), a resistor is required if you are using LEDs as indicators. If using lamps, make sure that the operating voltage of the lamp is equal to the supply voltage (V+). A table below provides suggested resistor values for typical LEDs.

Controller Supply Voltage (V+)	Recommended LED Resistor Ranges
12V	360—500 Ohm
24V	760—1K Ohm

**FIRE ALARM INTERFACE WIRE CONNECTION WITH AUTOMATIC RESET**

*Fire Alarm  
Terminal Block  
TRM9:*

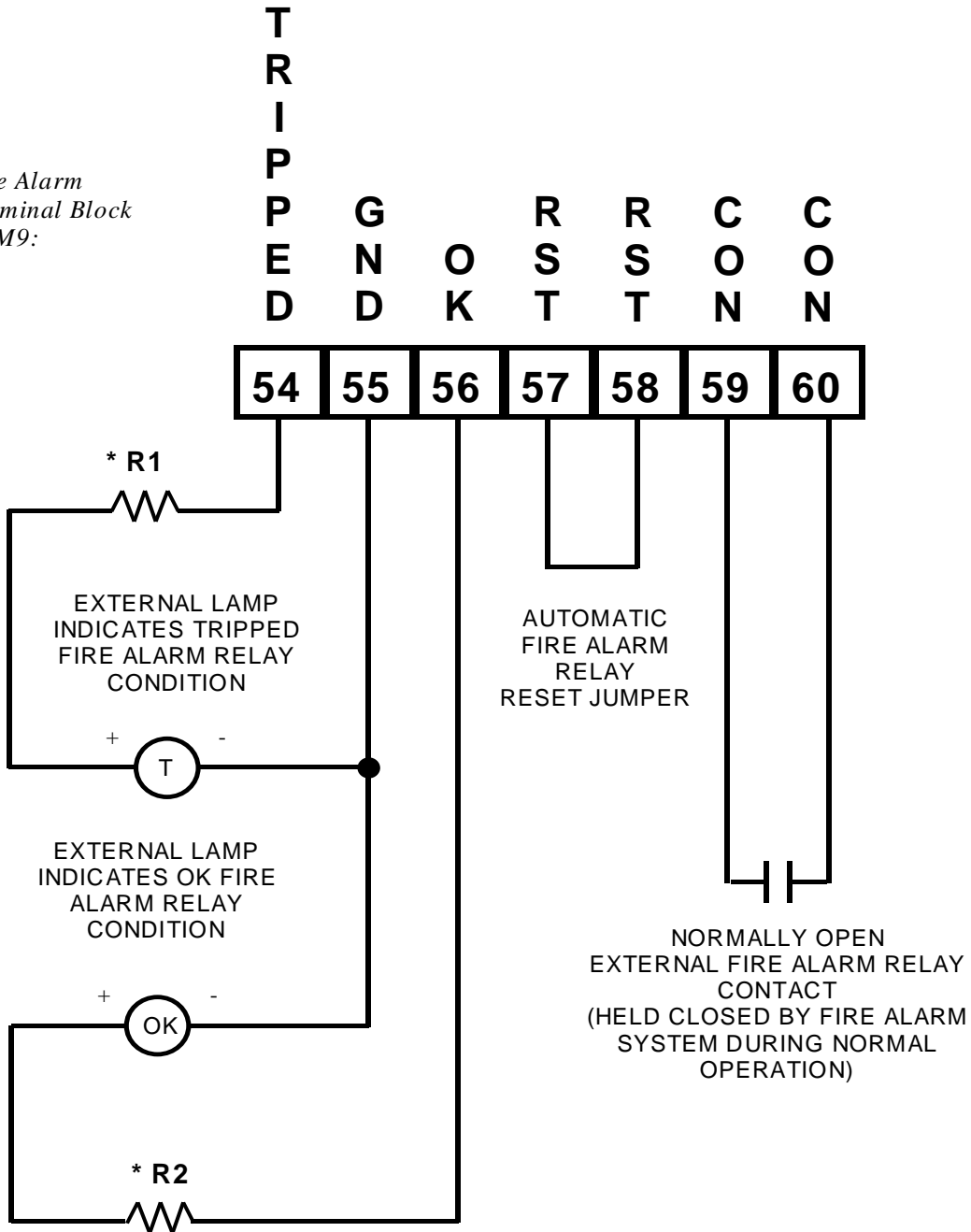

\* NOTE: Since the output voltage of the “TRIPPED” and “OK” terminals is (V+), a resistor is required if you are using LEDs as indicators. If using lamps, make sure that the operating voltage of the lamp is equal to the supply voltage (V+). A table below provides suggested resistor values for typical LEDs.

Controller Supply Voltage (V+)	Recommended LED Resistor Ranges
12V	360—500 Ohm
24V	760—1K Ohm

## **BATTERY PASS-THROUGH**

The battery pass-through feature may or may not be installed on your board. This feature uses two wires soldered at the top and on the bottom of the board that is used to pass a charging voltage to a battery backup. This feature is only installed at the factory and is used with Highpower Power Supplies.

## **LED INDICATOR FUNCTIONS**

<b><u>NAME</u></b>	<b><u>COLOR</u></b>	<b><u>FUNCTION</u></b>
LED1	Green	Lit when the Remote Release 1 Loop is Closed.
LED2	Green	Lit when the Remote Release 2 Loop is Closed.
LED3	Green	Lit when the Delayed Egress Request to Exit Loop is Closed.
LED4	Green	Lit when the Door Position Switch Loop is Closed.
LED5	Green	Lit when the Delayed Egress Reset Loop is Closed.
LED6	Green	Lit when the Fire Alarm Relay is Latched.
LED7	Green	Run Mode Indicator and Status LED
LED8	Amber	Key Press Indicator and Status LED
LED9	Red	Fire Alarm Tripped Indicator
LED10	Red	Error Mode Indicator and Status LED

# APPLICATIONS

## SAFELY WIRING THE CONTROLLER WITH AN ELECTROMAGNETIC LOCK AND A PNEUMATIC PUSHBUTTON

Relay Output 1  
Common Jumper  
JP7:

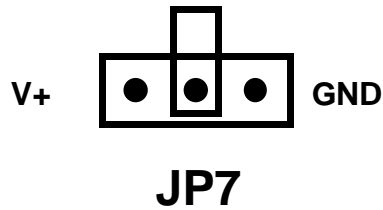

Note: This jumper is used to connect the common of Relay 1 to either Ground, V+ or neither. Remove the jumper for this configuration.

Relay Output 1  
Terminal Block  
TRM6:

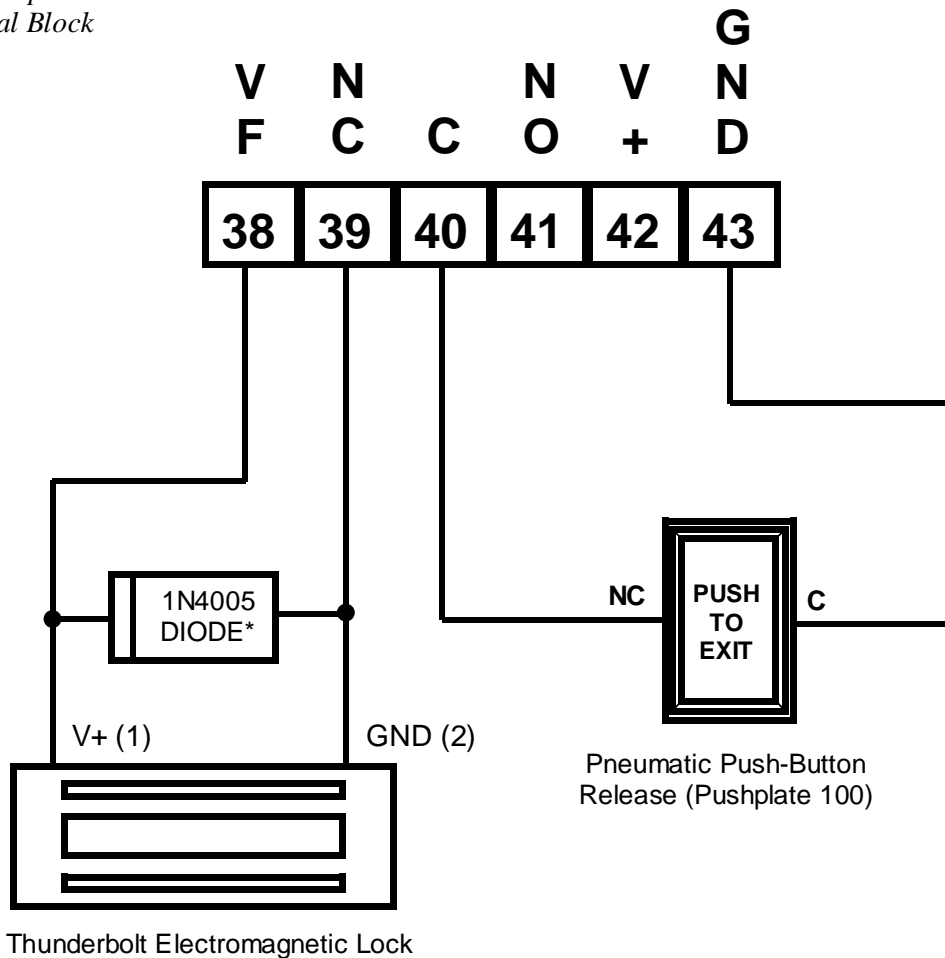

\* Diode may be required on certain lock models to provide surge suppression.

**SAFELY WIRING THE CONTROLLER WITH AN ELECTROMAGNETIC LOCK, PNEUMATIC PUSHBUTTON AND PIR SENSOR**

*Relay Output 1  
Common Jumper  
JP7:*

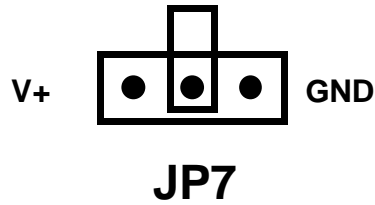

Note: This jumper is used to connect the common of Relay 1 to either Ground, V+ or neither. Remove the jumper for this configuration.

*Relay Output 1  
Terminal Block  
TRM6:*

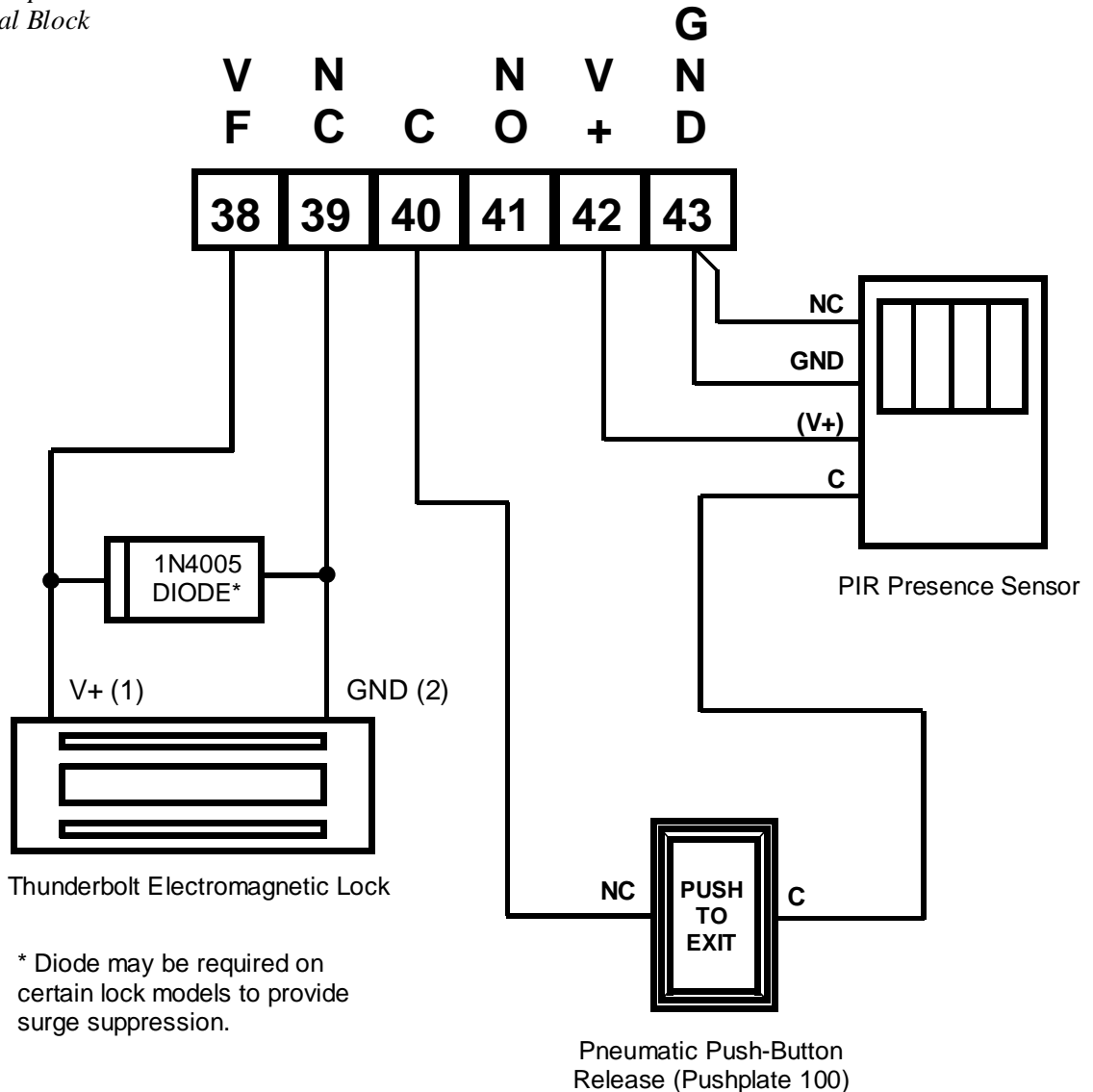

## USING TOGGLE CODES TO LEAVE A DOOR UNLOCKED

There are applications where a door in the system must be held open for an extended amount of time. You can use a second output of the controller to latch a door in an unlocked mode. By using a transistor output in conjunction with one relay output, you can program the controller to offer timed entry through one code and latched entry with a second code. In this case, one output is programmed to time the door, and a second output latches the door. Use the following wiring example to implement this function:

### WIRING DIAGRAM USING TOGGLING OUTPUTS TO LATCH A DOOR IN PASSAGE

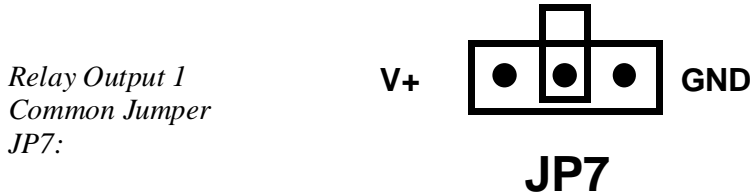

Note: This jumper is used to connect the common of Relay 1 to either Ground, V+ or neither. In this configuration, JP7 is not connected.

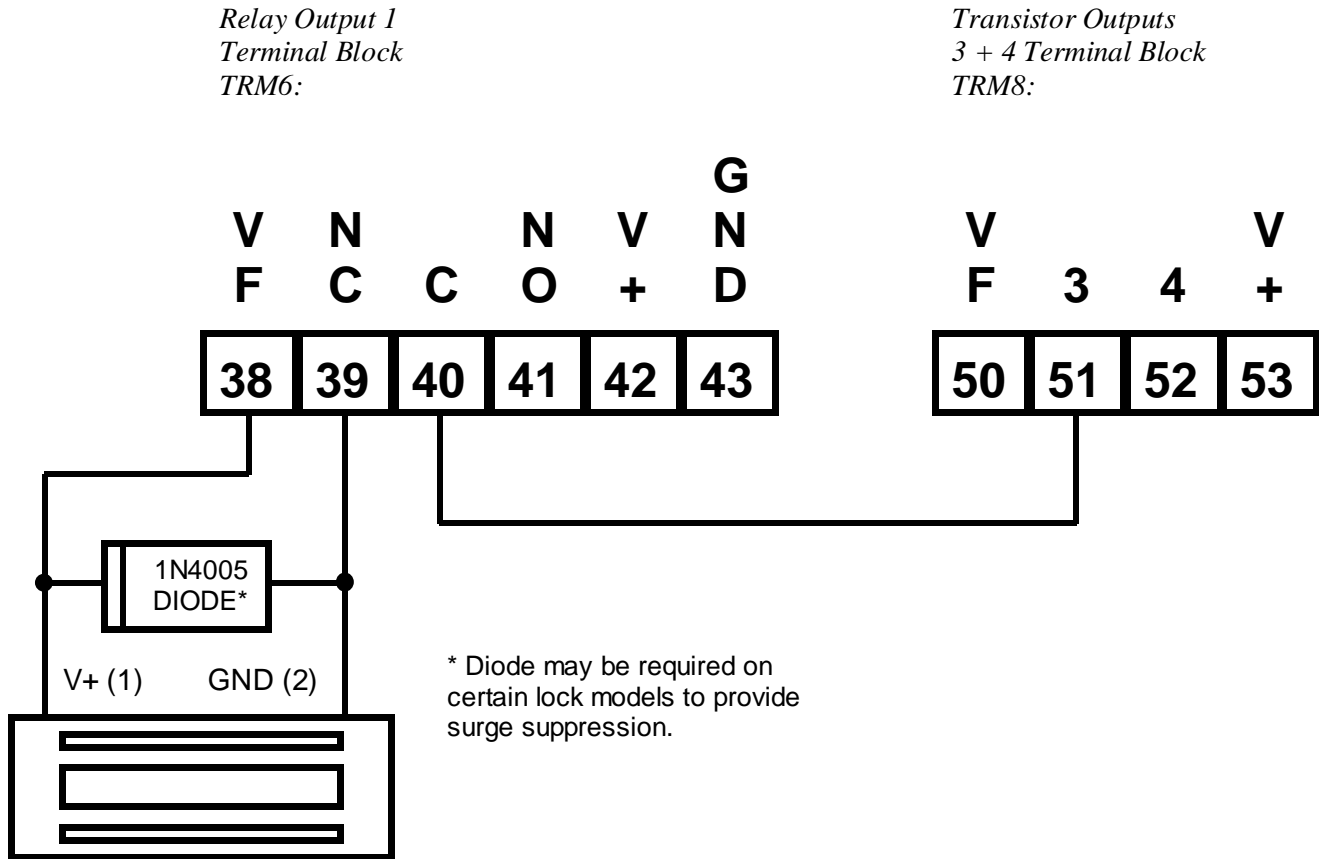

Thunderbolt Electromagnetic Lock or continuous duty Electric Strike

In this example, Relay Output 1 switches current that is provided from Transistor Output 3. If Output 1 is programmed to time the door, the door will unlock when codes that activate Output 1 are used. By programming Output 3 to toggle when activated, codes that activate Output 3 will cause the door to remain unlocked or locked, depending on the state of Output 3. When using this configuration for the first time, you may have to activate Output 3 with a code in order to turn Output 3 on, which will energize the magnetic lock.

## USING A TRANSISTOR OUTPUT TO CONTROL AN ELECTROMAGNETIC LOCK

The transistor outputs are designed to turn on during a timed unlock cycle. Because of this, many fail secure electric strikes can be directly connected to these outputs. In cases where Relay Outputs are not available and you must connect a fail-safe device to these outputs (such as a magnetic lock) you must use an external relay. The transistor outputs can be used to energize the external relay, cutting the power to the fail-safe device. Use the following wiring configuration to perform this function:

### TRANSISTOR OUTPUTS WITH FAIL-SAFE DEVICES WIRING DIAGRAM

*Transistor Outputs  
3 + 4 Terminal Block  
TRM8:*

*Relay Output 1  
Terminal Block  
TRM6:*

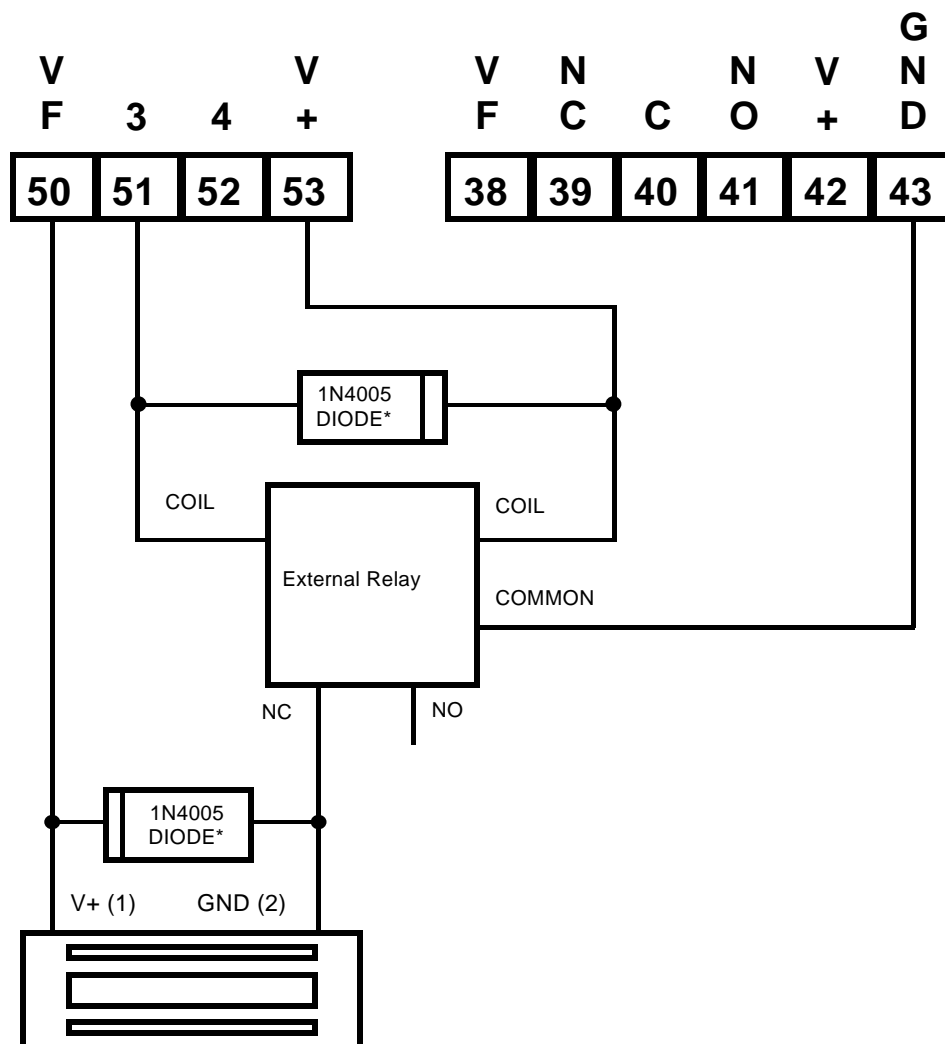

Thunderbolt Electromagnetic Lock or  
Other Fail -Safe Device

## **CONTROLLING FOUR DOORS WITH THE MODEL 3000**

The Wiegand Access Control Module of the Model 3000 Controller was designed to run two doors independently. Since the controller has four outputs, in some systems the controller can be used to control up to four doors. You can connect four Wiegand devices to the controller by connecting more than one device into each of the two Wiegand ports. You can also connect multiple Matrix Keypads into the Matrix Keypad Port. These configurations implemented correctly can be reliable, and can reduce overall system cost by using one controller to control four doors.

There are considerations when using the controller in these extended configurations. First, you must make sure that in all cases, the total current draw of all of the locking devices connected to the controller does not exceed the maximum current output of the system power supply. Also, make sure that all surge suppression diodes are installed on each of the locking devices.

Second, in this configuration you must connect more than one Wiegand device to a single Wiegand port. The controller allows the connection of multiple Wiegand devices, due to error detection mechanisms incorporated into the programming of the controller. This is acceptable if you recognize that all Wiegand devices connected to the same port, when swiped with the same card will unlock the door(s) that the card is programmed to unlock. Issues can arise in single-controller systems that use one card to unlock multiple doors. With systems that require two doors to unlock with the same card, make sure that each of the reader heads of the two doors are connected to different Wiegand ports. With other four-door systems, it is advisable that each card be programmed to unlock only one door in order to maintain security.

Third, if connecting fail-safe devices to transistor outputs, you must use external relays as described in the section called "Using a Transistor Output to Control an Electromagnetic Lock".

Lastly, although it is possible to connect multiple Matrix Keypads into the Matrix Keypad Port, doing this is not recommended. Any keypad connected to this port will send keystrokes back to the controller. If two people were to type codes at the same time into two matrix keypads connected to the same controller, the entries of both users would conflict with each other's input. Only systems where physical limitations stop users from typing into two keypads simultaneously (such as man-traps), should use multiple matrix keypads. If you require multiple user interfaces to operate independently use Wiegand devices. Call Highpower if you need assistance in configuring the controller with four doors.

## **MAN-TRAPS (FOR CLEAN ROOMS)**

There are applications where two doors are used as man-traps. In this configuration, two doors are located at different points of a common hallway, but only one door can be opened at a time. If one door is opened, the second door can not be unlocked. This application is often used in air locks for clean rooms in order to prevent contamination in the clean room. This application can be achieved with the controller by connecting two locking outputs in the following manner:

Relay Output 1  
Common Jumper  
JP7:

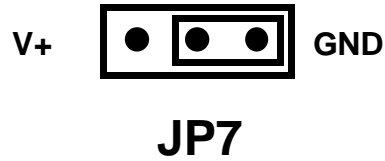

Note: This jumper is used to connect the common of Relay 1 to either Ground, V+ or neither.

Relay Output 1  
Terminal Block  
TRM6:

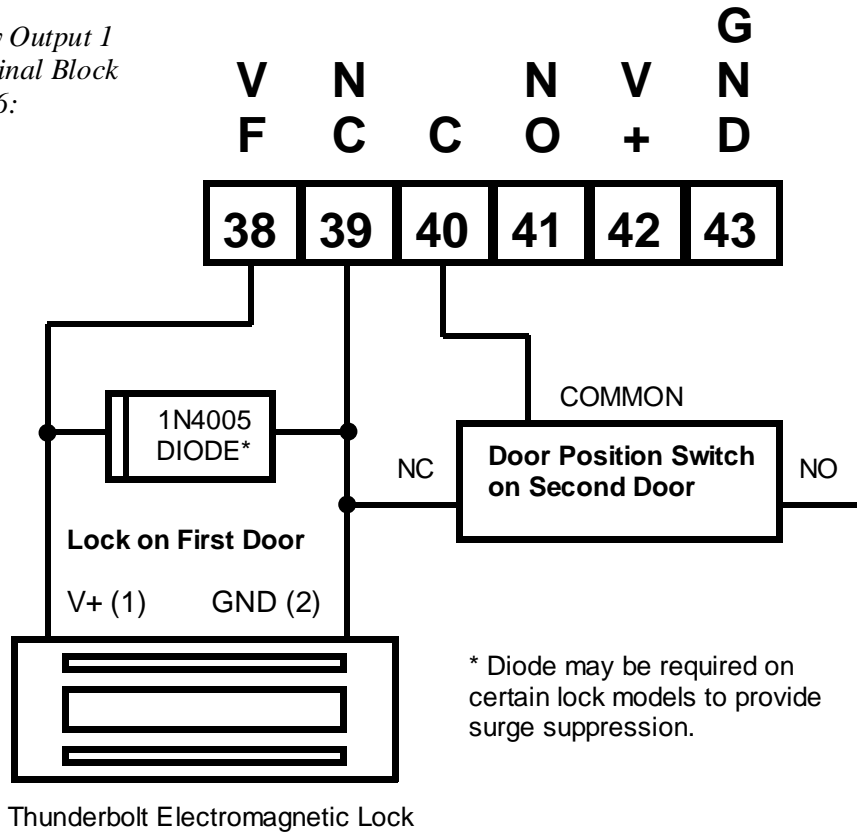

In this configuration, the Door Position Switch shunts the output relay when the second door is opened. This prevents the electromagnetic lock on the first door from de-energizing. When using this configuration, make sure that the door position switch has a maximum current rating that is larger than the current draw of the locking device. An external relay can be used in conjunction with a door position switch in order to increase the contact capacity of the door position switch. Contact Highpower if you require further assistance configuring this type of system.

### THIRD-PARTY ADD-ON PERIPHERALS

Developers interested in creating third-party expansion cards or other types of peripherals to this unit should contact Highpower directly. Highpower can arrange to create device drivers for third party devices, can provide interfacing information and can create custom programming for third-party

applications. We appreciate any interest in this area and appreciate any comments you may have about improving our products.

## CUSTOM WIRING DIAGRAMS AND UNIQUE APPLICATIONS

Highpower can provide design services for you application including wiring diagrams, installation procedures, and system integration. We offer turnkey solutions for your security requirements. Please feel free to contact Highpower directly for integration services.

## WARRANTY INFORMATION

Thank you for choosing a Highpower product! The Highpower Security Products, LLC Door Controller Model 3000 is manufactured to the highest quality standards to provide years of dependable service. The Model 3000 is warranted for two years from the date of shipment against defects in parts, workmanship and materials, when installed in accordance with instructions. Defects that occur within this warranty period, under normal use of the product, shall be repaired or replaced with a new unit, solely at our option. Warranty is void when product has been modified, damaged, abused, misused, subjected to abnormal use or neglect, or subjected to harsh operating environments out of the normal operating specifications.

No agent, employee or representative of Highpower Security Products, LLC has authority to bind Highpower Security Products, LLC to any oral affirmation, representation or warranty, other than set forth above. Highpower Security Products, LLC expressly disclaims all other warranties, expressed or implied, including but not limited to any implied warranties of merchantability or fitness for a particular purpose. "Fair-Safe" and "Fail-Secure" are definitions only. Use of these terms is not a performance warranty, but merely a descriptive term used to characterize a design feature.

## TROUBLESHOOTING ISSUES

This section describes troubleshooting information that is discovered through technical support calls with our customers. Highpower attempts to update this section on a regular basis with solutions to commonly asked technical support questions.

<b><u>Problem Description</u></b>	<b><u>Resolution</u></b>
The controller tends to reset from time to time when a door is released. The reset is detected when the LEDs light in sequence. Timing cycles become disrupted.	Make sure that there is adequate surge suppression on the electromagnetic locks or electric strikes that are connected to the controller. See the "Output Connection Diagrams" for information on how to add surge suppression to your system.
The controller displays a constant Amber LED when I am swiping cards for access, or performing other Wiegand Operations.	There is a problem with the Wiegand Port connection, or you are using the wrong type of Wiegand Card. Check the wiring on the Wiegand Ports and make sure all wires are connected properly. Make sure your Reader is a standard 26-Bit Wiegand type. If you are using proximity cards with your system, make sure the cards are encoded with a 26-Bit Wiegand format.
When I am Bulk-Enrolling, all three LEDs stay on. The Amber, Red and Green LEDs are all constant.	The memory is full. Try removing some cards that you are not using from memory.
When I am adding a card with a Shadow Card system, the Amber light is staying on after my swipe.	There are three causes for this condition. (1) The card is already in memory. Try the card in run mode to make sure it is working. (2) The memory is full. Try removing some cards that you are not using from memory. (3) There is a bad Wiegand connection or bad Wiegand data sent to the controller.

# TYPICAL SYSTEM RISER DIAGRAM

